

 **EURO
CHILLER**[®]
INTERNATIONAL COOLING

AXpro

PROCESS WATER CHILLERS

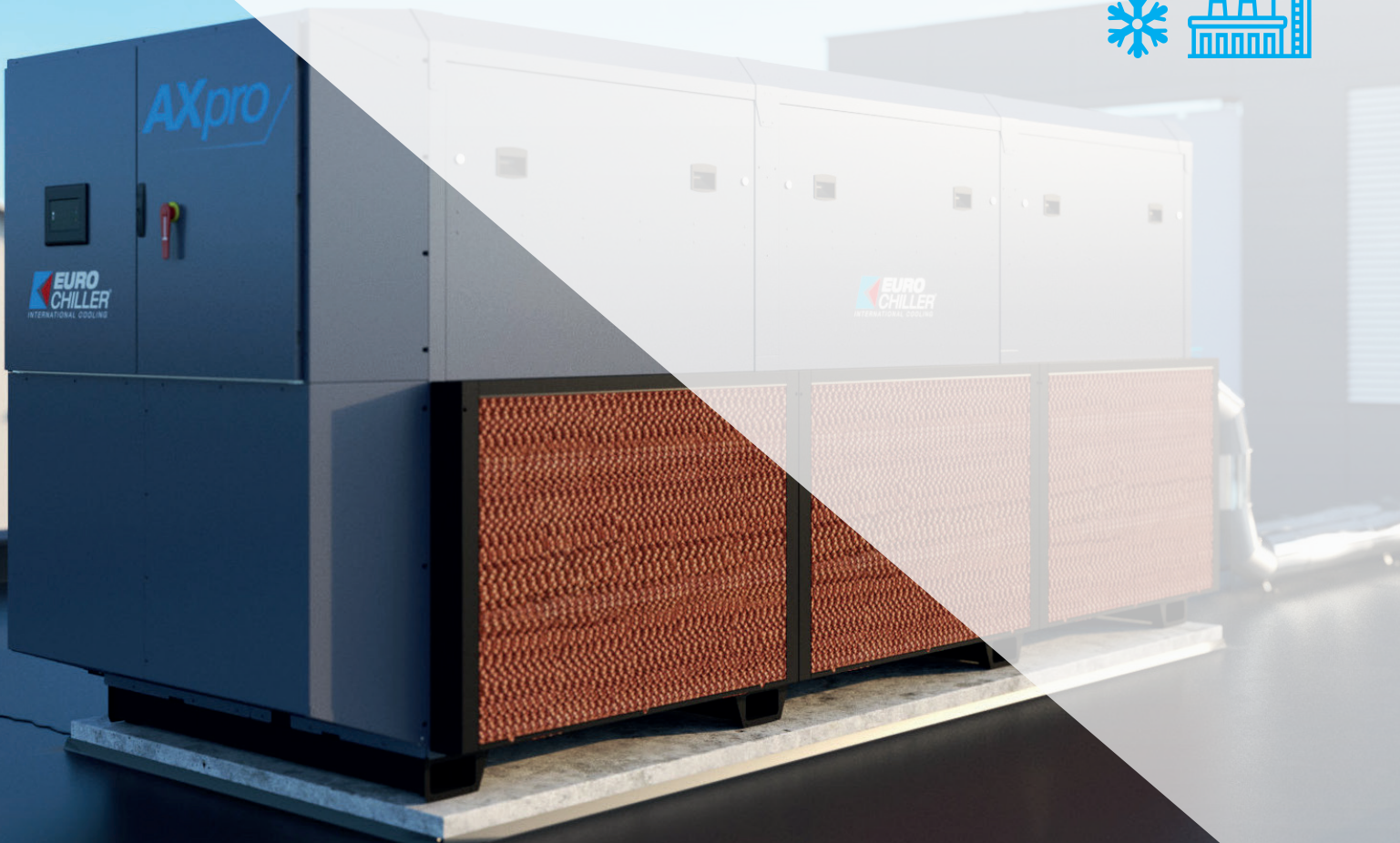



Serie AX. Refrigeratori per acqua di processo

Range AX.
Process water
chiller



AXpro

Axpro è un chiller per acqua di process con la possibilità di integrare in un'unica soluzione più tecnologie di risparmio energetico, per ottimizzare i consumi sia nel periodo invernale che in quello estivo.
Potenza frigorifera erogata da 75 a 320 kW

AXpro is a process water chiller that can integrate multiple energy saving technologies in a single solution to optimize consumption in both winter and summer seasons.
Coolin capacity from 75 to 320 kW



WIDE RANGE

Different sizes available
in 4 version

AIR COOLED

SCROLL COMPRESSORS

REFRIGERANT R407C

AXpro

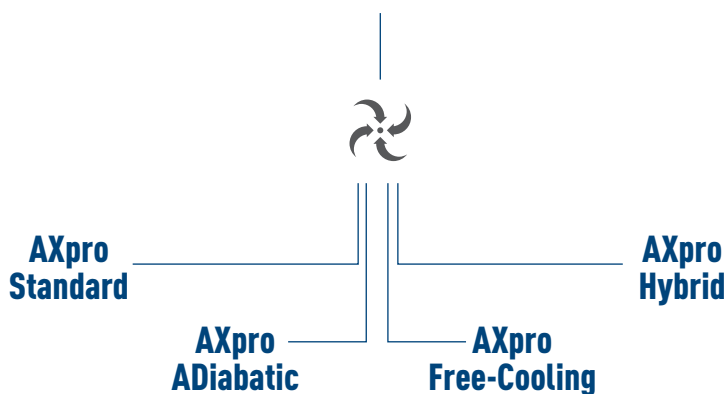

Approvazioni / Approvals:

- IEC
- PED 2014/68/UE
- Electrical cubich UL5080a approved
- **ECODESIGN**
COMPLIANT

Voltaggio disponibile / Voltage available:

- 400V – 50Hz
- 460V – 60Hz



AXpro



STRUTTURA

Il telaio è realizzato in acciaio zincato, verniciato a polvere epossipoliesteri. Il pannello di controllo è in grado di protezione IP54. Utilizzo sia interno che esterno.

STRUCTURE

The frame is made from galvanized steel, painted with epoxy powder coating. The control panel is IP54 rated. It can be installed outdoors and indoors.



COMPRESSORI

Configurazione di doppio circuito composto da compressori ermetici Scroll (Gas R407C) di nuova generazione ad alto rendimento.

COMPRESSORS

Twin circuit configuration with highly efficient, new generation, hermetic Scroll compressors (Refrigerant R407C).



VENTILATORI

Le unità sono dotate di ventilatori EC brushless.

FANS

Units are equipped with EC brushless fans.



CONDENSATORE

Condensatori a microcanali raffreddati ad aria e modulo idronico integrato permettono minori costi di manutenzione con una carica di refrigeratore ridotta.

CONDENSER

Microchannel condensers and integrated hydro module provide lower costs of maintenance with reduced refrigerant charge.



EVAPORATORE

Evaporatore a fascio tubiero robusto ad alta efficienza.

EVAPORATOR

Shell and tube evaporator with high efficiency.



POMPA E SERBATOIO

Pompa centrifuga con corpo e girante in acciaio inox. Serbatoio e pompa integrati nella versione standard.

PUMP AND TANK

Centrifugal pump with stainless steel body and impeller. Integrated tank and pump in standard version.



CONTROLLO

Il pannello touch screen IQ21 + Icons è progettato con algoritmi di efficienza energetica per controllare in maniera costante i parametri del chiller. L'interfaccia è semplice e intuitiva.

CONTROL

Touch screen panel IQ21 + Icons provides the algorithms to constantly control the chiller parameters. Interface is user friendly and interactive.

AXpro - S

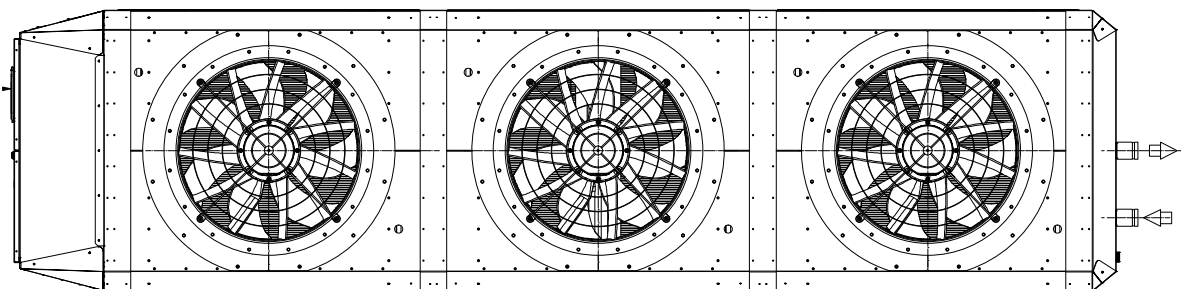
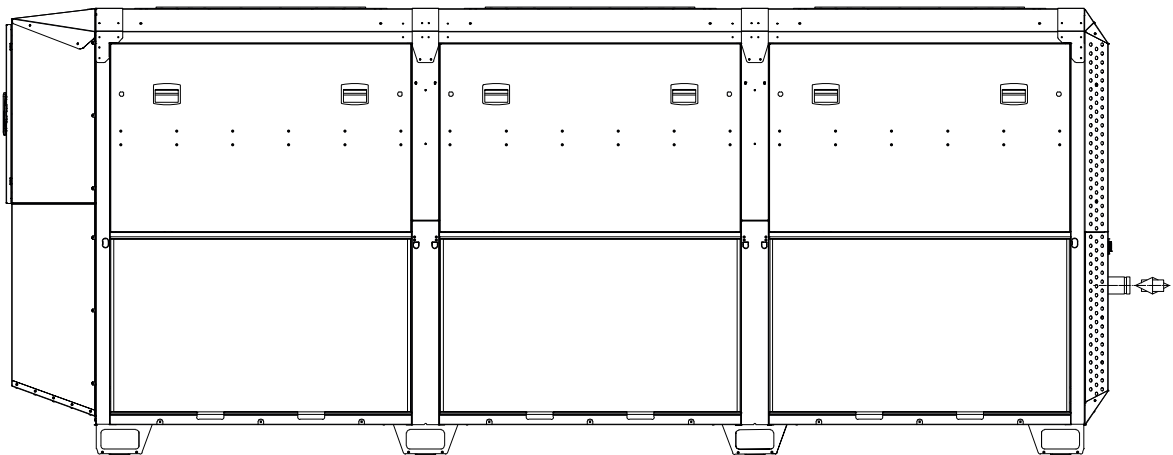
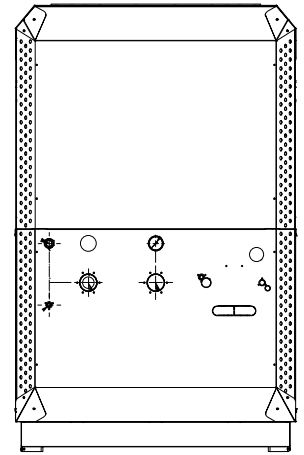
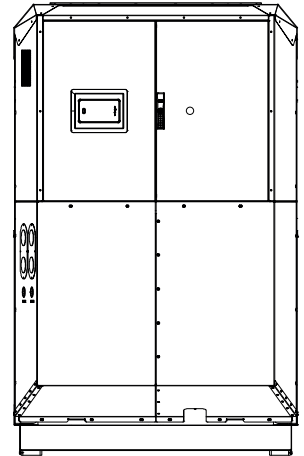

PROCESS WATER CHILLERS



AXpro - AD

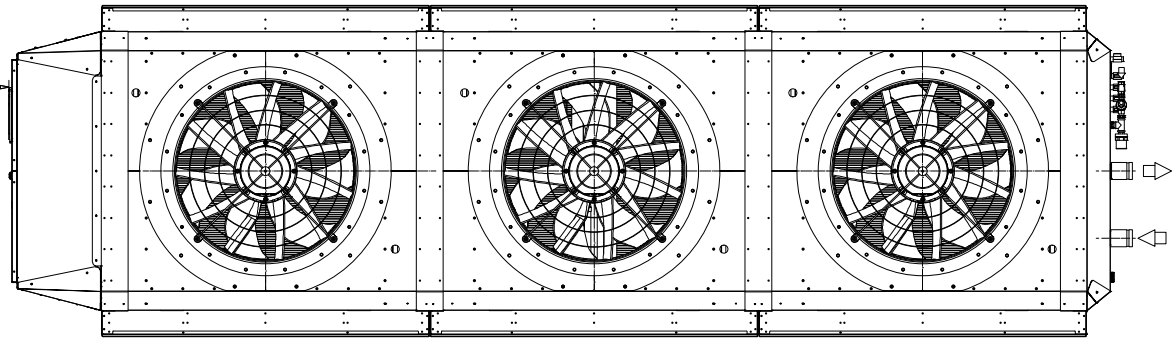
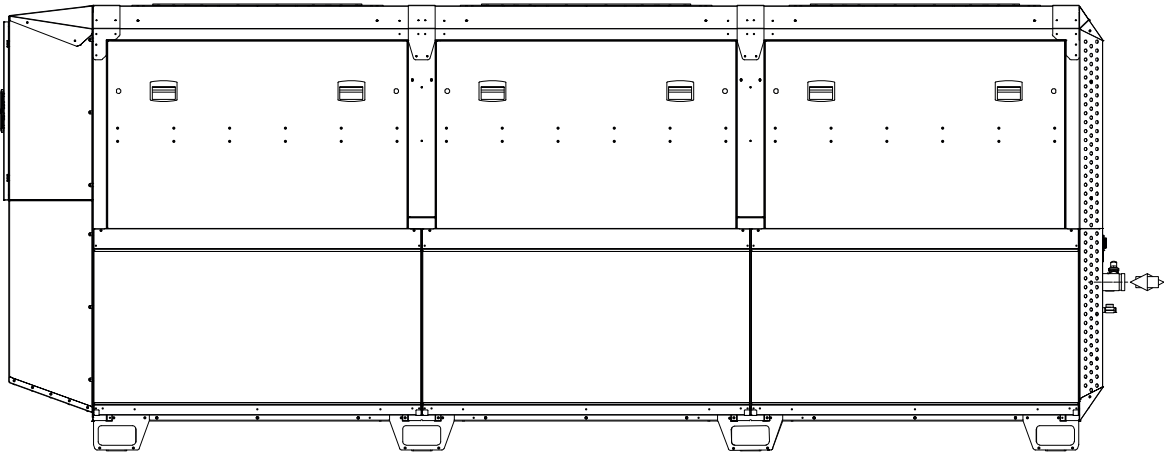
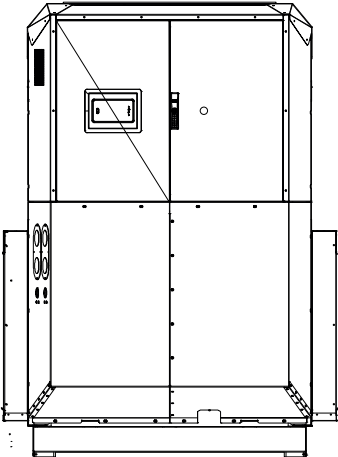
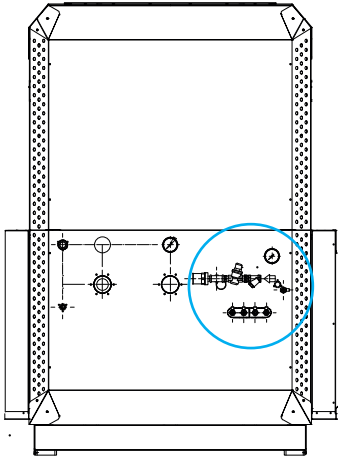
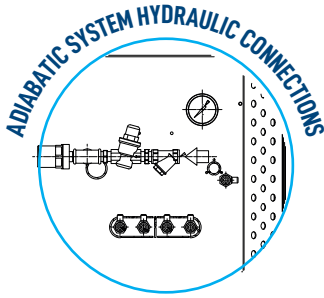

AXpro - FC

Free-cooling Integrate

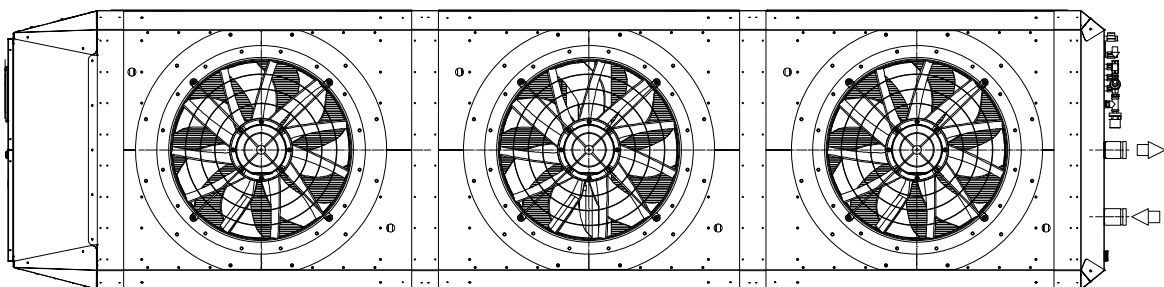
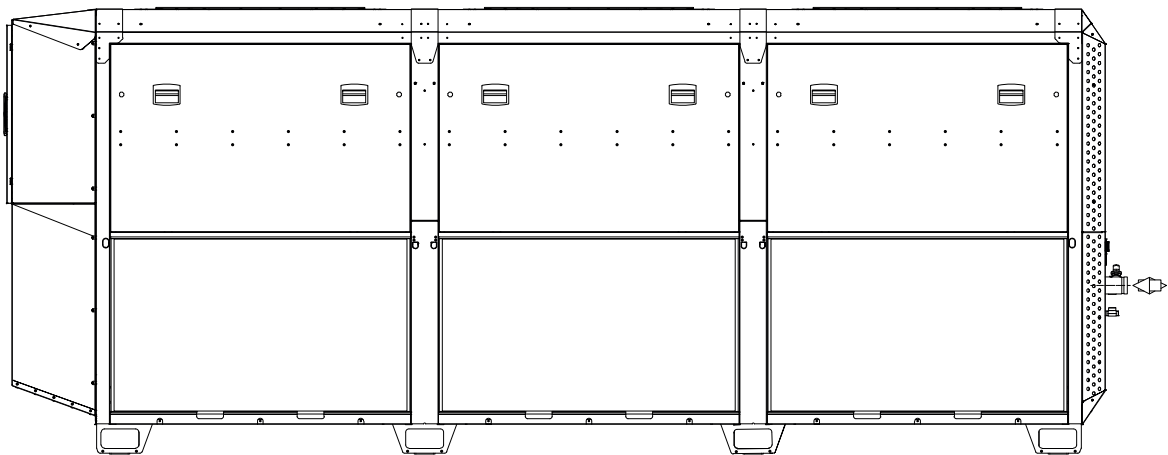
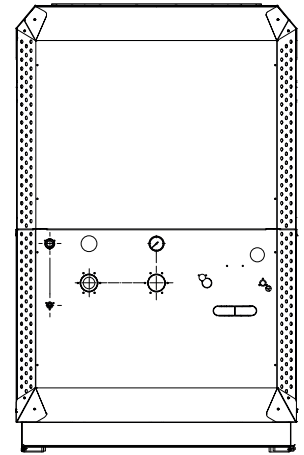
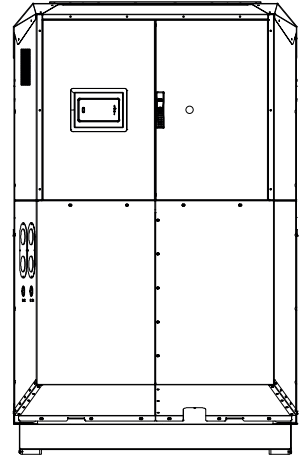

PROCESS WATER CHILLERS



AXpro - H

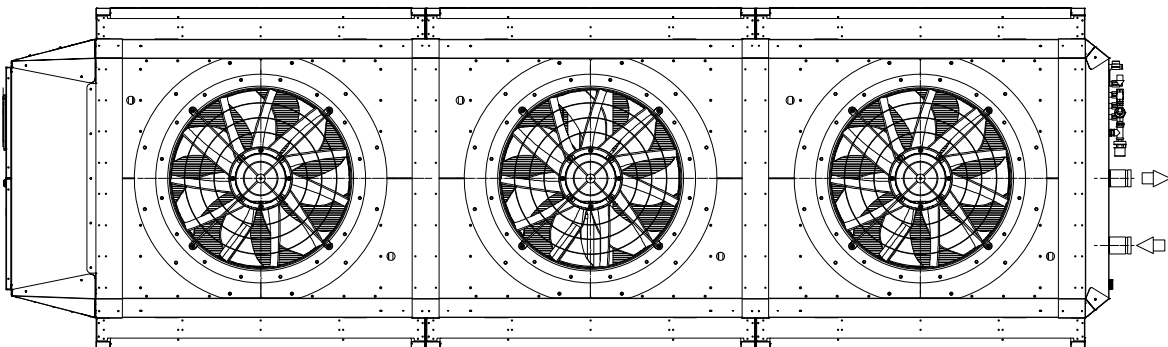
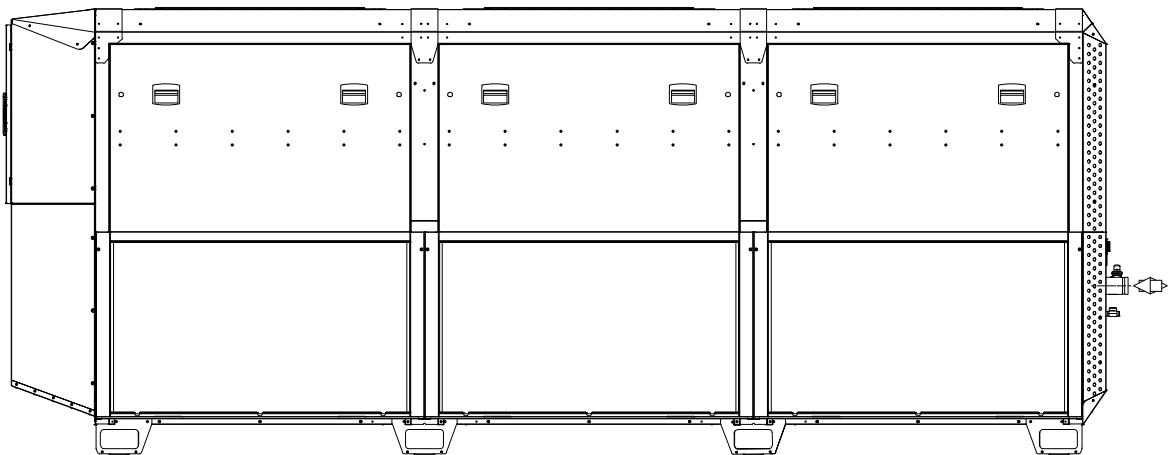
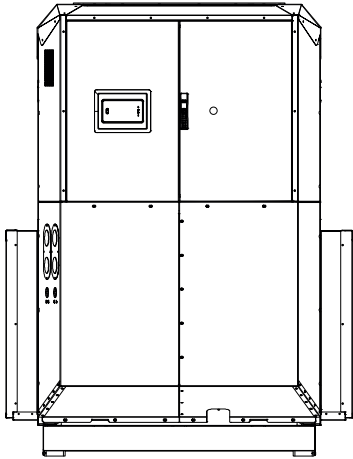
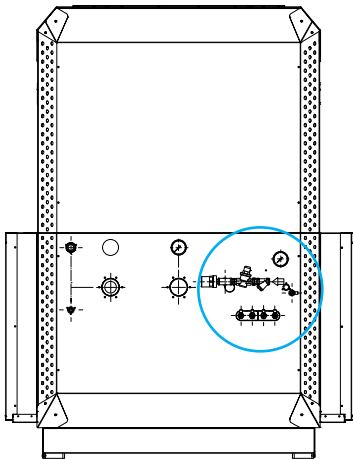
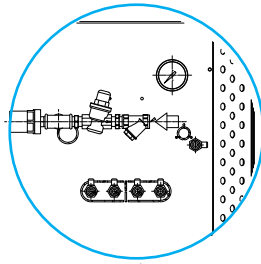

AXpro				80				95			
				S	AD	FC	H	S	AD	FC	H
COOLING SECTION	Potenza di raffreddamento (1)	Cooling capacity (1)	[kW]	75,1	78,6	74	77,9	95,7	97,5	93,6	97,7
	Input potenza nominale (1)	Nominal input power (fans and compressors) (1)	[kW]	18,5	16,2	18,5	16,6	23,4	22,2	23,6	22,5
	Potenza di raffreddamento (2)	Cooling capacity (2)	[kW]	55,6	57,5	54	57	63,2	67,2	60,9	66,2
	Input potenza nominale (2)	Nominal input power (fans and compressors) (2)	[kW]	19,5	17,4	20,1	17,9	24,2	22,7	24,4	23,1
	SEPR HT (3)	SEPR HT (3)		5,11	5,16	5,12	5,09	5,05	5,10	5,1	5,07
COMPRESSOR	Compressori (per circuito)	Compressors (each circuit)		Scroll				Scroll			
	Circuiti	Circuit		1				1			
	Controllo	Capacity control		2				2			
CONDENSER SECTION	Condensatore	Condenser		Fixed				Fixed			
	Protezione condensatore	Condenser protection		MCX				MCX			
	Numero di ventilatori	Number of fans		Epoxy Powder Painted				Epoxy Powder Painted			
	Ventilatori	Fans type		2				2			
	Diametro	Fan diameter	[mm]	Axial EC				Axial EC			
	Controllo	Fan control		800				800			
	Potenza nominale	Fan nominal power (each)	[kW]	EC_FAN				EC_FAN			
Temperatura minima ambiente (4)	Minimum ambient temperature (4)	[°C]	2,8				2,8				
SOUND	Sound Power Level (5)	Sound Power Level (5)	[dB(A)]	88,7	88,7	88,7	88,7	88,7	88,7	88,7	88,7
	Sound Pressure Level (6)	Sound Pressure Level (6)	[dB(A)]	60,7	60,7	60,7	60,7	60,7	60,7	60,7	60,7
HYDRAULIC SECTION	Pompa	Nominal power pump	[kW]	3				3			
	Seratoio	Tank Volume	[l]	370				370			
	Connessioni idrauliche in/out	Hydraulic connection-in/out		(2")/(2")				(2")/(2")			
	Collegamento idraulico-sistema di Aspirazione/Scarico adiabatico	Hydraulic connection-adiabatic Inlet/Discharge system		(1/2")-(1/2")				(1/2")-(1/2")			
ELECTRIC SECTION	Alimentazione	Power supply		400V±10% / 3Ph+PE / 50Hz				400V±10% / 3Ph+PE / 50Hz			
	Massima potenza input (7)	Max total power input (7)	[kW]	34,8				38			
	Massima corrente input (8)	Max. total current input (8)	[A]	58,7				65,1			
	Tensione ausiliaria	Auxiliary voltage		24V / 1Ph / 50Hz				24V / 1Ph / 50Hz			
	IP classificazione	IP rating		54				54			
SIZE AND WEIGHT	Lunghezza	Length	[mm]	3593	3593	3593	3593	3593	3593	3593	3593
	Larghezza	Width	[mm]	1249	1527	1249	1527	1249	1527	1249	1527
	Altezza	Height	[mm]	2000	2000	2000	2000	2000	2000	2000	2000
	Peso netto (9)	Net weight (9)	[kg]	1704	1831	1845	1971	1714	1840	1854	1980

1. Dati riferiti alle condizioni nominali di funzionamento: temperatura aria esterna 25 °C e temperatura acqua IN/OUT evaporatore 20/15 °C; 0% Glicole

2. Dati riferiti alle condizioni nominali di funzionamento: temperatura aria esterna 35 °C e temperatura acqua IN/OUT evaporatore 12/7 °C; 0% Glicole

3. Dato dichiarato in conformità al Regolamento Europeo (UE) 2016/2281 relativo ai requisiti di progettazione ecocompatibile per i prodotti di raffreddamento, fare riferimento al manuale per valori puntuali

4. versione STD min -10[°C], versione a bassa temperature -20 [°C]

5. Determinata sulla base di misure effettuate in accordo alle normative EN ISO 9614-1:2009 +EN12102-1:2017, I livelli sonori si riferiscono al funzionamento dell'unità nelle condizioni (2)

6. Valore medio calcolato ipotizzando l'unità in campo libero su piano riflettente ad una distanza di 10 m, il livello calcolato si riferisce ai valori riportati in (2) e (5)

7-8. Dati riferiti alla configurazione con pompa 3 bar, le informazioni sugli assorbimenti possono cambiare in funzione della configurazione della pompa e dell'opzione a temperatura ambiente -20°C. Si prega di contattare il supporto tecnico per i dettagli.

9. Peso riferito alla configurazione con pompa 3 bar e serbatoio

110				135				170				230				270				320			
S	AD	FC	H	S	AD	FC	H	S	AD	FC	H	S	AD	FC	H	S	AD	FC	H	S	AD	FC	H
107,9	118	106,6	111,3	135,7	147,8	132,2	139,9	171,5	186,7	168,9	177,2	222	232	217,6	227,3	267,1	275,3	262,6	275	298	322,9	293,4	319,2
25,4	22,4	25	22,4	31,4	28,9	31,1	28,4	41,9	38,5	42	38	50,8	42,9	51,1	44,4	72,3	63,9	70,6	65,4	83,9	77,2	85,1	79,9
75,7	82,8	72,2	78,8	97,7	108,4	94,1	102	119	134,3	117,9	125,1	152	166,7	149,9	162,1	187	203,5	180,5	200,5	207	228,8	204,8	226,1
26,2	23,5	27,3	23,6	34,6	31,6	36,6	30,9	45,7	39,6	48,6	38,9	53	45,7	54,4	47,4	75,1	64,4	76,4	66,1	86,8	73,6	87,4	76,3
5,20	5,23	5,14	5,09	5,21	5,25	5,12	5,1	5,01	5,03	5,02	5,01	5,10	5,15	5,12	5,11	5,07	5,13	5,09	5,07	5,04	5,11	5,08	5,05
Scroll				Scroll				Scroll				Scroll				Scroll							
1				1				1				1				2							
2				2				2				2				2							
Fixed				Fixed				Fixed				Fixed				Fixed							
MCX				MCX				MCX				MCX				MCX							
Epoxy Powder Painted				Epoxy Powder Painted				Epoxy Powder Painted				Epoxy Powder Painted				Epoxy Powder Painted							
3				3				3				3				3							
Axial EC				Axial EC				Axial EC				Axial EC				Axial EC							
800				800				800				910				910							
EC_FAN				EC_FAN				EC_FAN				EC_FAN				EC_FAN							
2,8				2,8				2,8				3,2				3,2							
-20				-20				-20				-20				-20							
91,8	91,8	91,8	91,8	91,8	91,8	91,8	91,8	91,8	91,8	91,8	91,8	96,7	96,7	96,7	96,7	96,7	96,7	96,7	96,7	96,7	96,7	96,7	96,7
63,8	63,8	63,8	63,8	63,8	63,8	63,8	63,8	63,8	63,8	63,8	63,8	68,7	68,7	68,7	68,7	68,7	68,7	68,7	68,7	68,7	68,7	68,7	68,7
4				5,5				5,5				5,5				5,5							
440				440				440				500				500							
(2 1/2")-(2 1/2")				(2 1/2")-(2 1/2")				(2 1/2")-(2 1/2")				(4")-(4")				(4")-(4")							
(1/2")-(1/2")				(1/2")-(1/2")				(1/2")-(1/2")				(1/2")-(1/2")				(1/2")-(1/2")							
400V±10% / 3Ph+PE / 50Hz				400V±10% / 3Ph+PE / 50Hz				400V±10% / 3Ph+PE / 50Hz				400V±10% / 3Ph+PE / 50Hz				400V±10% / 3Ph+PE / 50Hz							
47,2				64,3				75,5				89,7				115,9	65,5	115,9	115,9	129,1	241,1	129,1	129,1
83,2				104,1				123				148,9				190,2				209,4			
24V / 1Ph / 50Hz				24V / 1Ph / 50Hz				24V / 1Ph / 50Hz				24V / 1Ph / 50Hz				24V / 1Ph / 50Hz				24V / 1Ph / 50Hz			
54				54				54				54				54				54			
5049	5049	5049	5049	5049	5049	5049	5049	5049	5049	5049	5049	5064	5064	5064	5064	5064	5064	5064	5064	5064	5064	5064	5064
1249	1527	1249	1527	1249	1527	1249	1527	1249	1527	1249	1527	1749	2029	1749	2029	1749	2029	1749	2029	1749	2029	1749	2029
2000	2000	2000	2000	2000	2000	2000	2000	2000	2000	2000	2000	2299	2299	2299	2299	2299	2299	2299	2299	2299	2299	2299	2299
2233	2348	2440	2555	2427	2422	2634	2749	2415	2590	2682	2797	3081	3207	3388	3514	3348	3474	3655	3781	3396	3522	3549	3830

1. Data referring to nominal conditions: air temperature 25 °C, evaporator IN/OUT water temperature 20/15 °C; 0% Glycol
2. Data referring to nominal conditions: air temperature 35 °C, evaporator IN/OUT water temperature 12/7 °C; 0% Glycol
3. Data declared in accordance with European Regulation (EU) 2016/2281 relating to ecodesign requirements for cooling products, refer to the manual for specific values
4. STD version min -10[°C], low temperature version -20[°C]
5. Determined on the basis of measurements according to EN ISO 9614-1:2009 +EN12102-1:2017, the sound levels are reported when the unit operates in conditions (2)
6. Average value calculated assuming the unit in free field on a reflecting surface at a distance of 10 m, the calculated level refers to the values in (2) and (5)
- 7-8. Data referring to the configuration with 3 bar pump, the datas may change depending on the pump configuration and the -20°C ambient temperature option. Please contact technical support for details.
9. Weight referred to the configuration with 3 bar pump and tank

State-of-the-art component engineering

Model	Free-cooling	Adiabatic systems
AXpro S		
AXpro FC	•	
AXpro AD		•
AXpro H	•	•

COMPRESSORE REFRIGERANTE COMPLETAMENTE SIGILLATO ERMETICAMENTE

La gamma AXpro dispone di 2 circuiti frigoriferi con 2 o 4 compressori scroll a seconda della resa frigorifera, che consentono una ottimizzazione dei consumi energetici e una migliore continuità di lavoro.

- Nessuna manutenzione richiesta
- Versione insonorizzata opzionale, con cuffie fonoassorbenti.

HERMETIC SCROLL COMPRESSORS

The AXpro range has 2 refrigeration circuits with 2 or 4 scroll compressors depending on output needed, which allow optimization of energy consumption and continuous uptime.

- No maintenance required;
- Optional soundproof version, with sound-absorbing headphones.

VALVOLA DI ESPANSIONE ELETTRONICA

- Garantisce la massima efficienza energetica, rapidità di azionamento e minor tempo di manutenzione.

ELECTRONIC EXPANSION VALVE

- Guarantees maximum energy efficiency, speed of operation and less maintenance time;

PIPING SEMPLIFICATO

- Collegamenti idraulici disponibili in diverse versioni: filettatura BSP e NPT, flange UNI o ASME;
- Carico acqua manuale o automatico semplificato sia per il circuito idraulico del chiller che per il sistema adiabatico;
- Bypass idraulico di sicurezza.

SIMPLIFIED PIPING

- Hydraulic connections available in different versions: BSP and NPT thread, UNI or ASME flanges;
- Simplified manual or automatic loading of water for both the chiller hydraulic circuit and the adiabatic system;
- Hydraulic safety bypass.

PROCESS WATER CHILLERS



SISTEMA DI PRERAFFREDDAMENTO ADIABATICO (VERSIONE AXpro AD – AXpro H)

I refrigeratori della serie AXpro AD uniscono alle qualità costruttive e funzionali dei modelli standard l'efficienza energetica ottenuta mediante il preraffreddamento evaporativo dell'aria in ingresso ai condensatori, ottenendo anche nei mesi estivi, quando l'assorbimento elettrico dei compressori raggiunge l'apice, quelle condizioni di funzionamento e di moderato assorbimento elettrico che normalmente si possono registrare solo nei mesi più freddi.

ADIABATIC PRECOOLING SYSTEM (AXPRO AD – AXPRO H VERSION)

Chillers of the AXpro AD series combine the construction and functional qualities of the standard models with the energy efficiency gotten through evaporative pre-cooling of the air entering the condensers, granted even in the summer season, when the electrical absorption of the compressors reaches its peak, those operating conditions and moderate electrical absorption that can normally only be reached in the colder months.

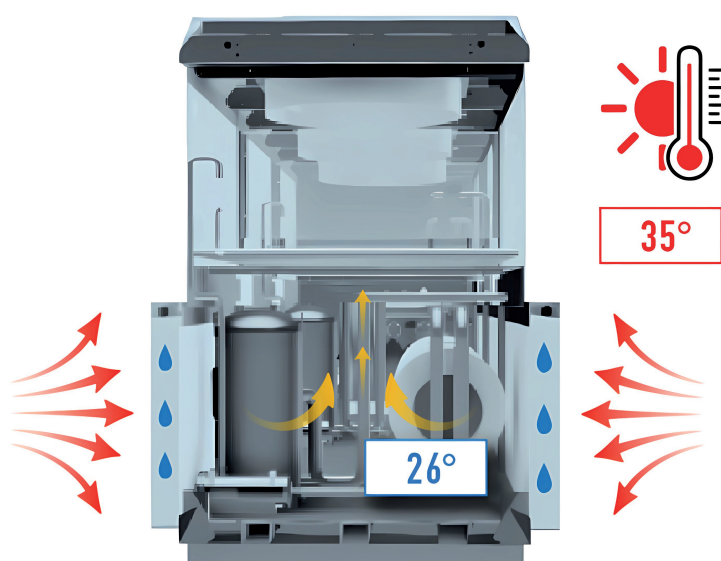

SISTEMA DI PRERAFFREDDAMENTO FREE COOLING INTEGRATO (VERSIONE AXPRO FC – AXPRO H)

I refrigeratori della serie AXpro FC si differenziano dai normali refrigeratori per la presenza all'interno della macchina di una batteria alettata con scambio termico aria/acqua (free-cooler). L'obiettivo è quello di sfruttare la temperatura dell'aria mossa dai ventilatori per raffreddare l'acqua che attraversa la batteria alettata (free-cooler) producendo così acqua fredda al minor costo possibile e conseguendo un importante risparmio energetico.

INTEGRATED FREE COOLING SYSTEM (AXPRO FC – AXPRO H VERSION)

Chillers of the AXpro FC series differ from normal chillers due to the presence inside the machine of a finned coil with air/water heat exchange (free-cooler).

The aim is to exploit the temperature of the air moved by the fans to cool the water that passes through the finned coil (free-cooler), thus producing cold water at the lowest possible cost and achieving significant energy savings.

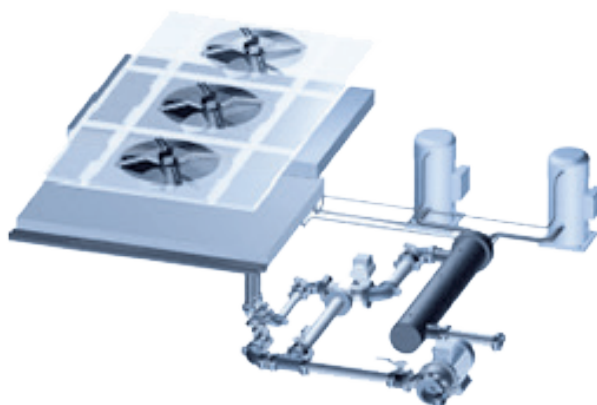

SISTEMA HYBRID (VERSIONE AXPRO-H)

EUROCHILLER propone inoltre la versione AXpro-H, massima espressione del risparmio energetico attuabile su un chiller per usi industriali.

L'abbinamento dei sistemi adiabatico e free-cooler integrati in un'unica soluzione consente di raggiungere valori di EER assolutamente impensabili in altre soluzioni.

HYBRID SYSTEM (AXPRO-H VERSION)

EUROCHILLER also offers the AXpro-H version, the maximum expression of energy saving that can be achieved on a chiller for industrial use.

The combination of the adiabatic and free-cooler systems integrated in a single solution allows achieving EER values absolutely unthinkable in other solutions.

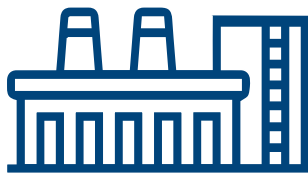

VARIETÀ DI APPLICAZIONI INDUSTRIALI

I componenti utilizzati nella fabbricazione del refrigeratore ne consentono l'utilizzo in un'ampia gamma di applicazioni e settori industriali.

L'utilizzo di un evaporatore a fascio tubiero consente di utilizzare efficacemente questo refrigeratore in vari processi produttivi, in circuiti idraulici chiusi e in circuiti idraulici aperti.

VARIETY OF INDUSTRIAL APPLICATIONS

The components used in the manufacture of the chiller allow it to be used in a wide range of applications and industrial sectors.

The use of a shell'n'tube evaporator makes it possible to effectively use this chiller in various production processes in both closed and especially open hydraulic circuits.

MASSIMO RISPARMIO ENERGETICO

La gamma AXpro è conforme alla Direttiva EcoDesign 2021 (EU 2009/125/CE) rispettando l'indice di prestazione energetica stagionale (SEPR) per raggiungere il massimo livello di risparmio energetico.

MAXIMUM ENERGY SAVINGS

AXpro range is compliant with the EcoDesign Directive 2021 (EU/2009/125/EC) respecting the seasonal energy performance index (SEPR1) to achieve the maximum level of energy

Eurochiller s.r.l.

Via Milano 69, 27030 Castello d'Agogna (PV), Italia
Tel +39 0384.298985 • Fax +39 0384.298984

Service +39 0384.298981 | eurochiller@eurochiller.com

www.eurochiller.com

C.F. e Reg. Imprese Pavia: 02057160968 - REA 189197 Pavia - P.I. 01482170188
Cap. Soc. € 51.000,00 i.v. | Società del Gruppo Atlas Copco